

PATTERN: TRAIL Horse WALK & TROT

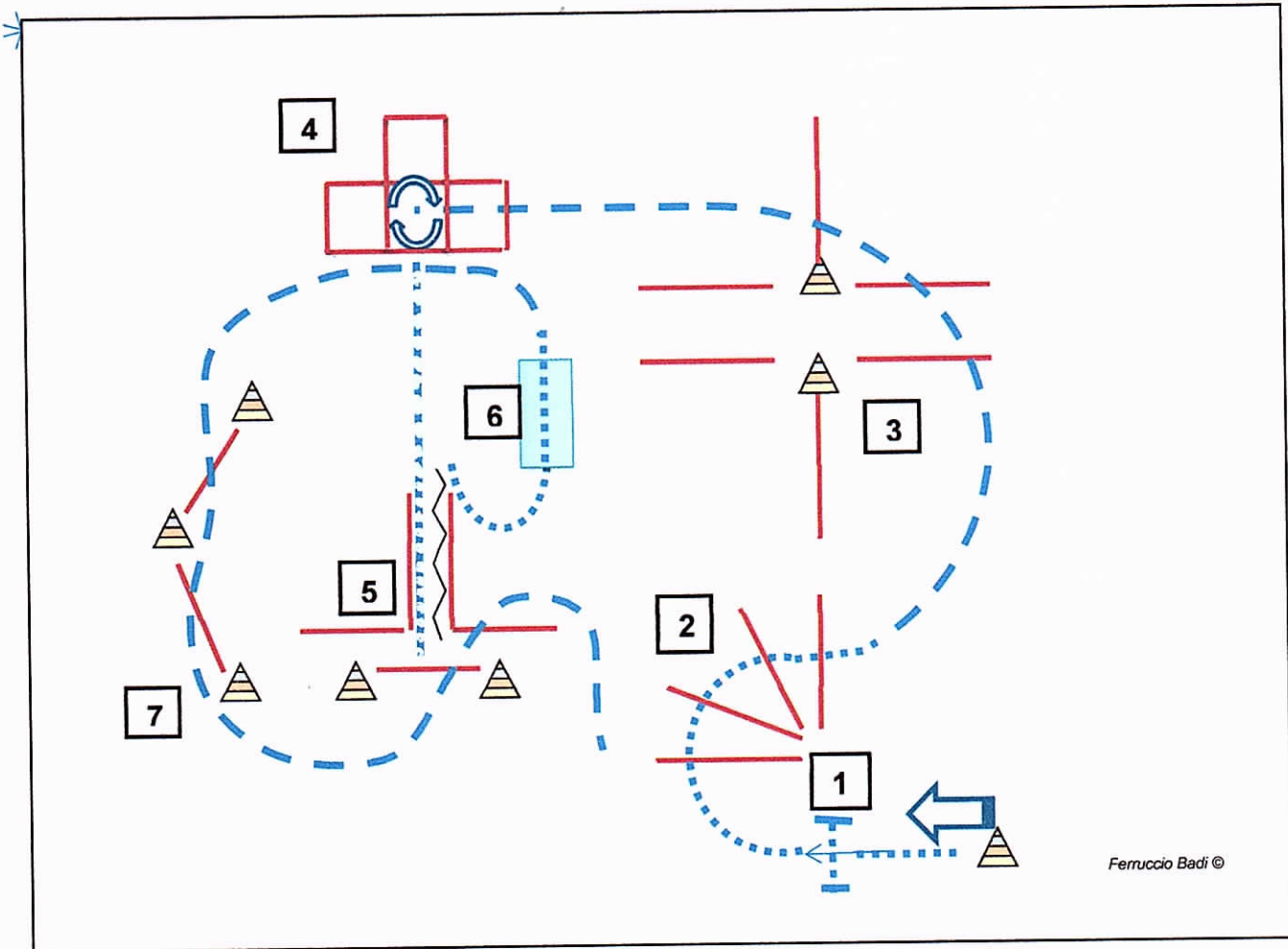

Ferruccio Badi ©

..... Walk



marker

- - - jog,

~~~~~ back,

### Pattern:

1. Walk the gate
2. walk over 4 logs,
3. jog over 5 logs
4. perform 270° right turn walk out,
5. walk in the chute, stop and back out
6. walk on the bridge
7. jog on the four logs

## PATTERN: TRAIL Horse A1 W YOUTH – A1 W AMATEUR

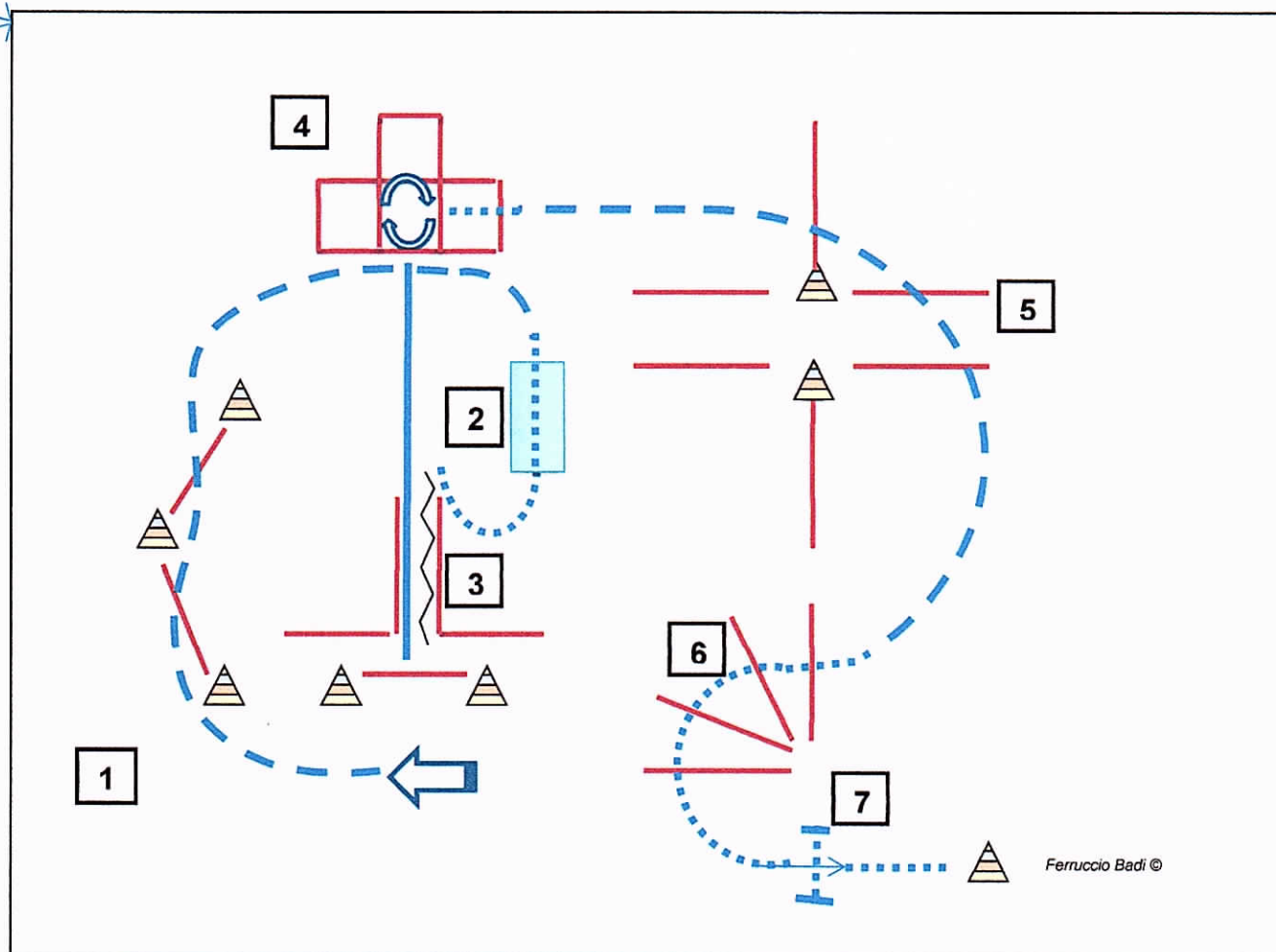

..... Walk



marker

- - - jog,

^ ^ ^ back,

### Pattern:

1. jog over the two logs
2. walk on the bridge
3. back in and lope out the chute,
4. walk into the box, perform 45° right turn walk out,
5. jog over 3 logs
6. walk over 4 logs,
7. Walk the gate

**PATTERN: Trail Horse**  
**NOVICE YOUTH – NOVICE AMATEUR**

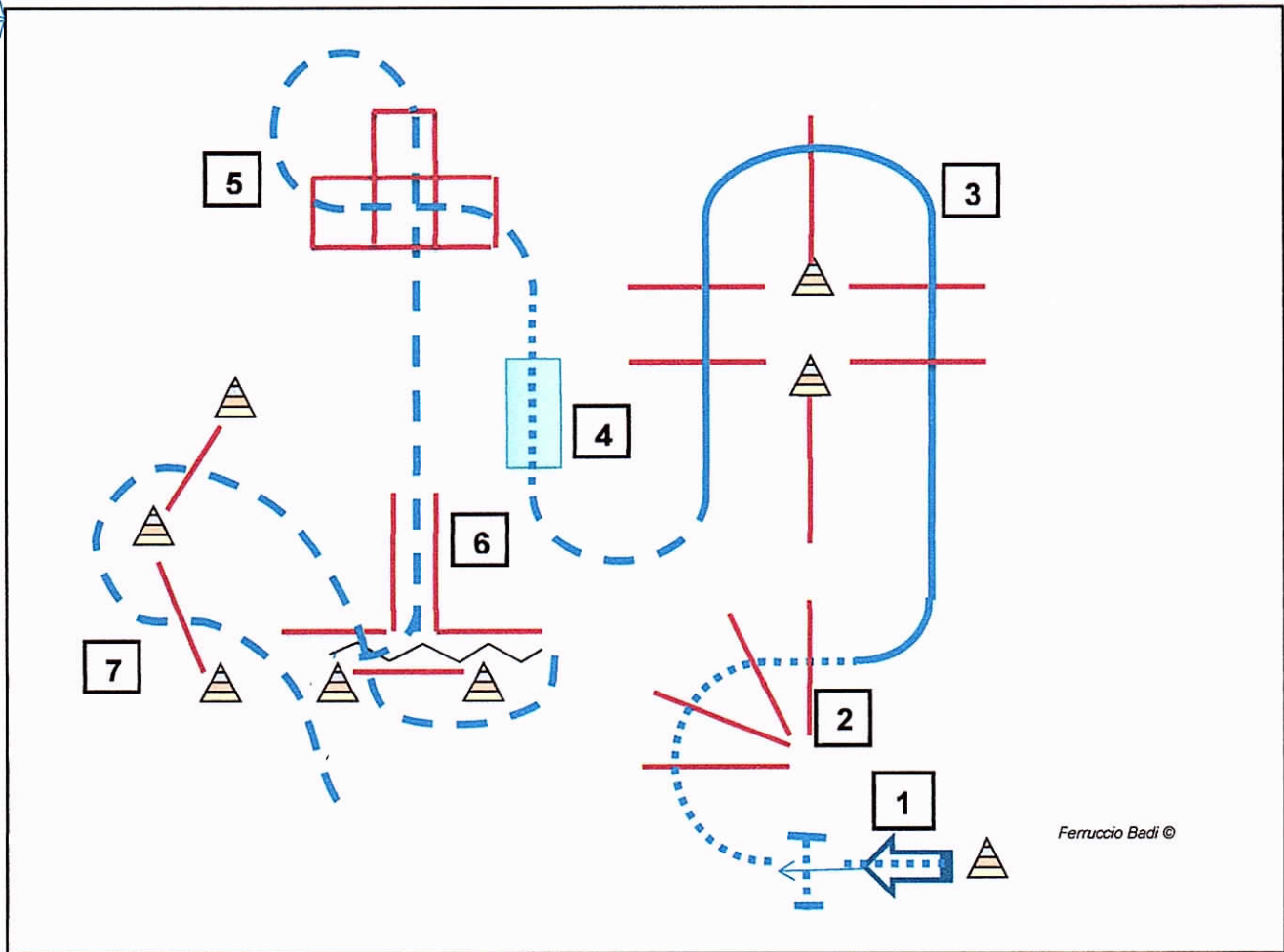

Ferruccio Badi ©

..... Walk

- - - jog,

~~~~~ back,

 marker
 lope

Pattern:

1. ready to the gate, walk the gate
2. Walk Over
3. left lope and lope over, break down to jog and proceed to the bridge,
4. walk the bridge
5. jog over the boxes,
6. jog in the chute, to the right and back till the end
7. jog over, till the marker

**PATTERN: Trail Horse
YOUTH – AMATEUR**

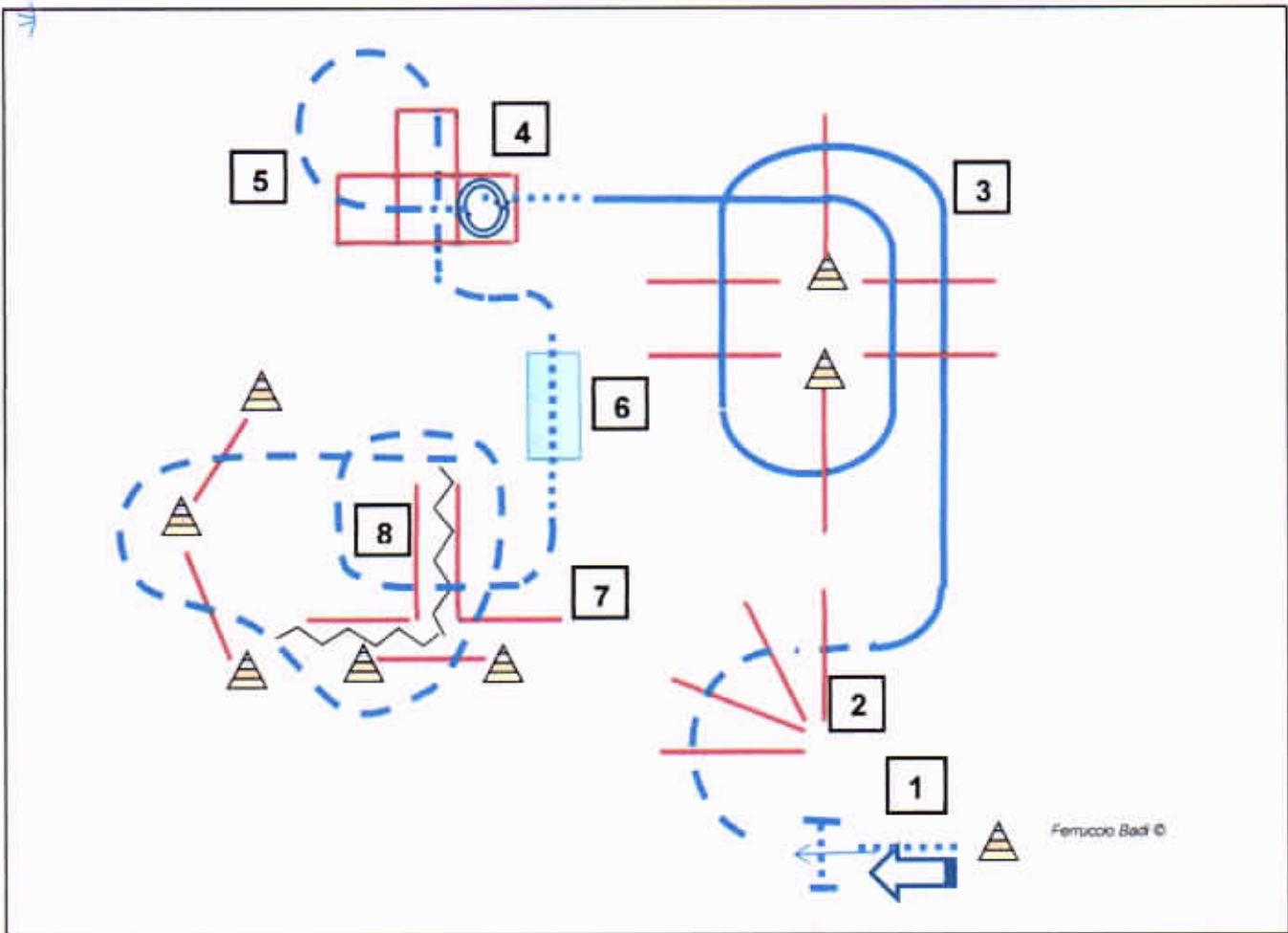

..... Walk

- - - jog,

~~~~~ back,

 marker

 lope

**Pattern:**

1. ready to the gate, walk the gate
2. jog over
3. lope over
4. walk in the first box 360° turn to the right, walk exit
5. Jog over the boxes
6. walk the bridge
7. jog over,
8. back "L" and exit to the walk

## PATTERN: Trail Horse OPEN

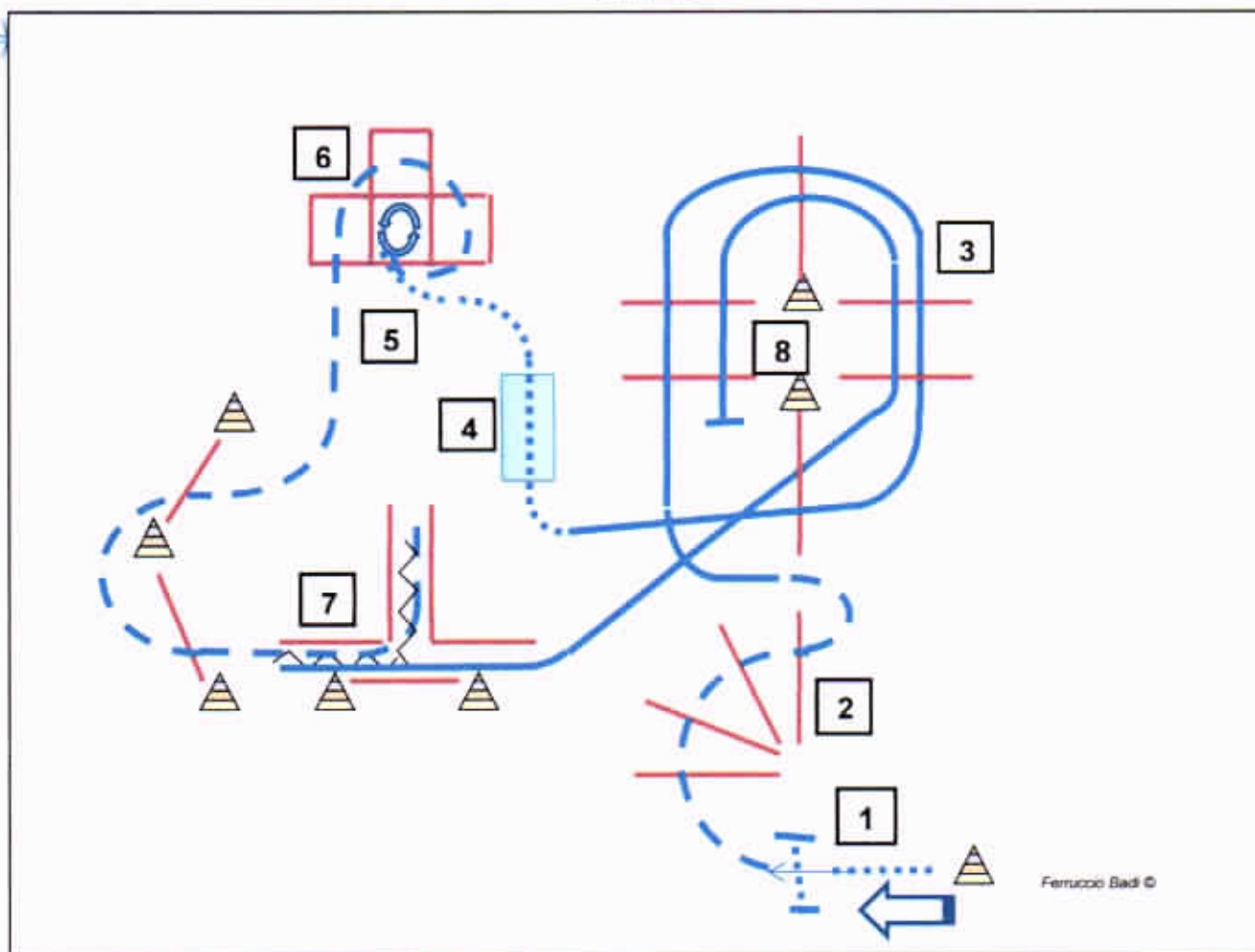

..... Walk

- - - jog,

~~~~~ back,

 marker

 lope

Pattern:

1. walk the gate
2. jog over the logs
3. right lope on the logs,
4. walk the bridge
5. walk in the box and perform 450° turn on the right, jog out
6. jog over the logs, inside the chute
7. back "L"
8. left lope out from the chute, and over the logs, stop